



Arrêt d'urgence à câble Belt Conveyor Pull Rope Switch

HEN



Application

Kiepe pull-rope emergency stop switches type HEN are used in accordance with the requirements of EN 620 as well as BGI 710 and Machinery Directive 2006/42/EC and meet the requirements in the in conformity with DIN EN ISO 13850 as emergency stop devices safety objectives of Low Voltage Directive 2006/95/EC. They must only be used in control electrical circuits.

The devices are suitable for outdoor use and applications where the ambient temperature varies considerably.

With the pull-rope system functionally aligned, the emergency stop signal can be triggered over a distance of up to about 100 m for each switch.

The HEN aluminum housing offers space for up to 3 simultaneously switching NO and NC contacts. Taking into consideration the safety data and maintenance recommendations, the pull-rope emergency stop switch type NTS can be used in safety circuits in accordance

with **Din En iSo 13849 up to performance level e (ple)**.

Function

The pull-rope emergency stop switch is actuated by a pull rope connected on both sides of the red release lever. The contacts are actuated by a spring supported cam disc (snap action function). At the same time, up to three NC and NO contacts are actuated simultaneously and a cross comparison of the contacts can be performed with an external control unit.

The emergency stop signal is performed with positive-making normally closed (NC) contacts in accordance with the closed circuit principle.

After the emergency stop function is triggered, the switching mechanism is locked in the shut-off position "0". When the blue reset lever is actuated in switch position "1", the switching contacts are reactivated and the conveyor belt is prepared for being turned back on again.

Resetting the pull-rope emergency stop switch must not cause the conveyor system to start up.

Technical Data

Designation	Pull-rope emergency stop switch type HEN – emergency stop device with latching function
Type of actuation	Bidirectional; spring-loaded ("snap action")
Complies with	DIN EN ISO 13850; DIN EN 60204-1; DIN EN 60947-5-5; DIN EN 60947-5-1; EN 620; BGI 710
Suited for	Control units and systems in accordance with DIN EN 60204

Mechanics

Enclosure	Aluminum GK-AISi 12
Finish	DD-paint Enclosure – yellow (RAL 1004), release lever – red (RAL 3000), reset lever – blue (RAL 5010)
Mounting	2 slotted holes for M8 screws
Installation position	Horizontal, tilt angle up to about 15°
Pull-rope length	Up to approx. 100 m
Actuation force	30 N ± 10 N
Weight	1.7 kg

Electrical system

Switching system	Up to 3 NC and NO contacts; cam operated positive-making switches
Cable entry	Threaded holes 2x M25 x 1.5 with each 1x screwed cable gland: sealing area Ø 11 mm to Ø 16 mm; 1x dummy screw
Utilization category	AC-15: 230 V; 6 A DC-13: 110 V; 1.1 A
Connection cross section	1 mm ² to 2.5 mm ²
Protective conductor connection	In the casing; M4
Rated insulation voltage U_i	400 V
Rated impulse withstand voltage U_{imp}	2.5 kV, degree of pollution III
Conventional thermal current I_n	16 A
Contact reliability	1 2 million switching operations

Ambient conditions in accordance with Din En 60947-5-5

Permissible ambient temperature	-25 °C ... +70 °C
Extended ambient temperature range	-40 °C ... +70 °C (type HEN 7xx)
Protection rating	IP 67 in accordance with EN 60529

Safety data in accordance with Din En iSo 13849 and En 61062

Safety functions	Emergency stop incl. latching Manual reset
Usable in accordance with DIN EN ISO 13849-1	Up to PLe (depending on customer application)
B10d value	24,000 actuations

SEIEction tABle

Switch type	Contact configuration		Integrated signal lamp 	Temperature range -40 °C ...+70 °C	Ventilation membran	Order number
	NO	NC				
HEN 001	1	1				91.043 450.001
HEN 002	2	2				91.043 450.002
HEN 004	1	1	x			91.043 450.004
HEN 005	2	2	x			91.043 450.005
HEN 018	2	2			x	91.043 450.018
HEN 701	1	1		x		91.043 450.701
HEN 702	2	2		x		91.043 450.702

Further models available on request

Equipment options:

Gold-plated contacts

Ventilation membran

Reset with square instead of lever

Signal lamps for 230 V, 110 V, or 24 V

LED signal lamps in AC/DC version for 230 V or 24 V

Devices for two-wire bus line

Spare parts and accessories:

Screwed cable gland M25 x 1.5 (sealing area 11 mm to 16 mm)	113.52.02.20.01
Screw plug M25 x 1.5	113.52.87.20.02
Replacement lamp: light bulb 230 V / 5W - E14	330.03.06.15.00
Ventilation membran M12 x 1	580.00.16.01.01
Cover HEN including seal and screws	93.066 839.004

Mounting

Pull-rope emergency stop switches of types HEN are each fastened to the substructure in installation position with 2 M8 screws, tensioned by tension spring² between the anchor hook³ and centered between the anchor hook³ of the pull-rope system (see the mounting diagram).

After the tension spring² have been adjusted, the actuation

Electrical connection is performed with the device open using the force and path for triggering the switch must be tested to ensure compliance with specified requirements. joints of the switching elements and the lamp fitting (option)

Mounting DiAgram

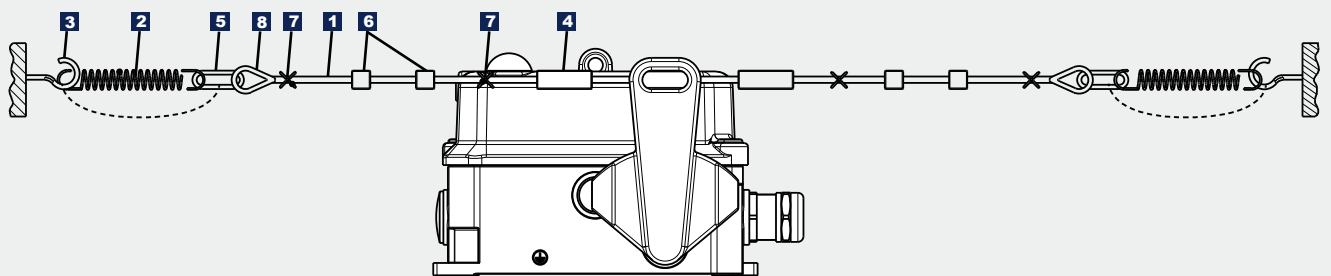

- | | | |
|-------------------------|-----------------------|------------------|
| 1 Pull rope | 4 Turnbuckle | 7 Clamp |
| 2 Tension spring | 5 Quick link | 8 Thimble |
| 3 Anchor hook | 6 Rope support | |

connEction DrAwing

Switching elements in accordance with DIN EN 60617
(the maximum configuration is shown)

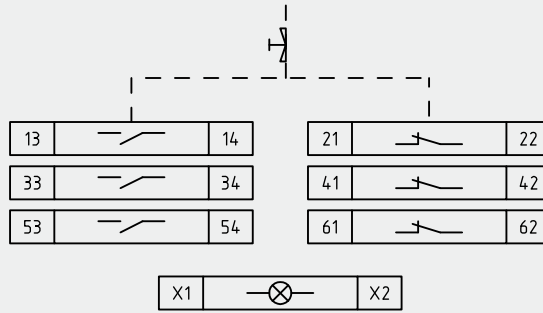

DiMEnSions

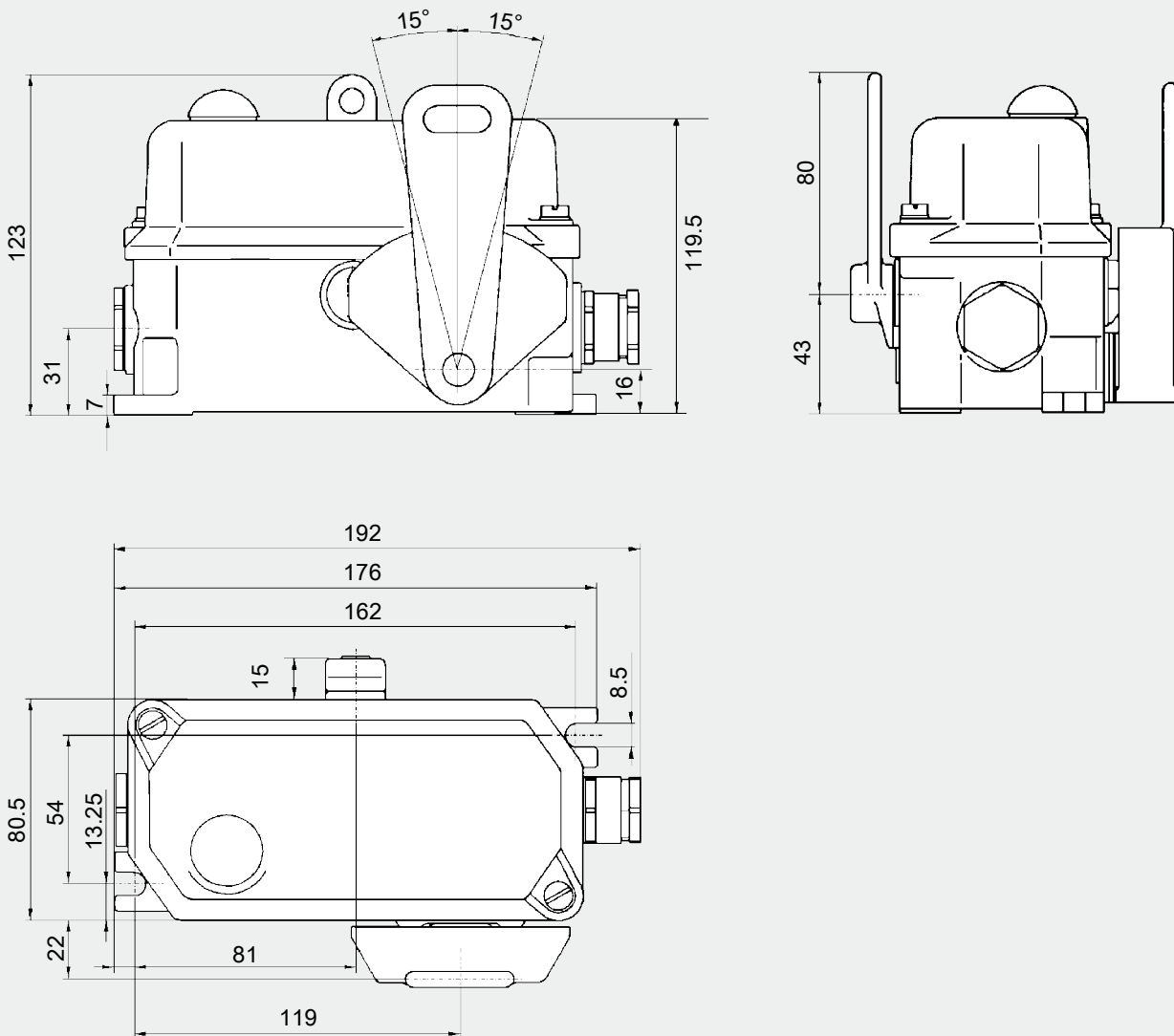

Subject to change without notice.

TELEMETRIX SAS FRANCE, BP1118 FR-78370 PLAISIR

Tel. (+33) (0) 972 11 00 03 Fax (+33) (0) 972 11 00 03 www.telemetrix.fr contact@telemetrix.fr

RCS B 418 256 814 SIRET 418 256 814 00041